

备注:

1. L1/L2, C3, C4根据测试结果调整
2. 如过没有金属外壳, PGND与GND 连接。

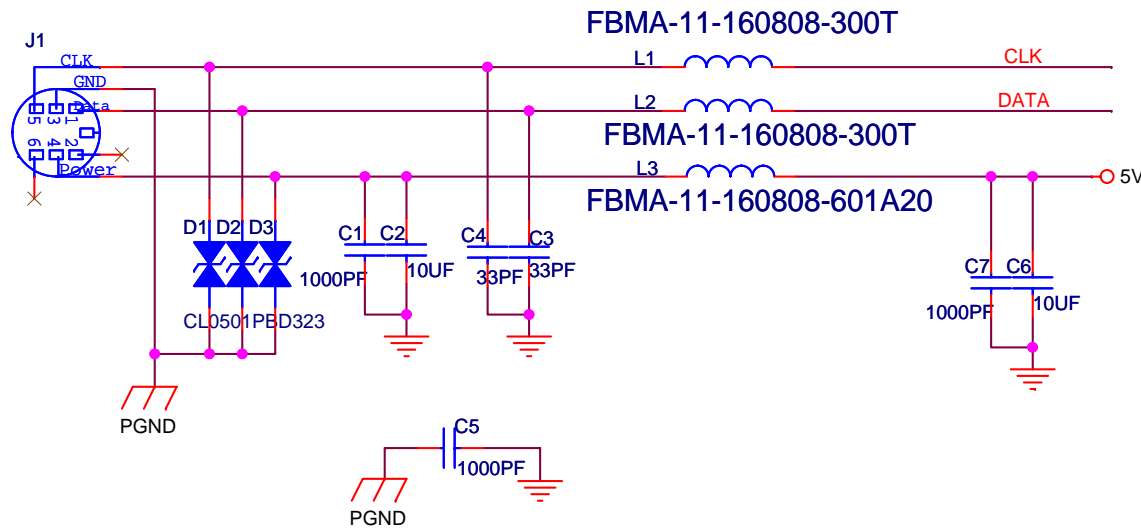

全方位电磁兼容 (EMC) 方案供应商

电话: 18681505326

邮箱: axmsales008@163.com

邮箱: www.axmchip.com

Title		
PS2接口EMC设计参考电路		
Size A	Document Number	Rev 1.1
Date:	Sheet 1 of 1	