



【 SPECIFICATION FOR APPROVAL 】

SAN TUO P/N	ANR5040 Series	DATE	2015/11/10	REV	B
--------------------	-----------------------	-------------	-------------------	------------	----------

变更履历

版本	变更项目	变更前内容	变更后内容	变更日期
A	初版	—	—	2015/11/10
B	B版本	测试频率100KHZ/0.25V	测试频率100KHZ/1V	2017/1/17



【SPECIFICATION FOR APPROVAL】

SAN TUO P/N	ANR5040 Series	DATE	2015/11/10	REV	B
-------------	----------------	------	------------	-----	---

Wire Wound SMD Power Inductors–ANR Series

Operating temperature range: -40°C~+125°C (Including self-heating)

1.PART NUMBERING SYSTEM

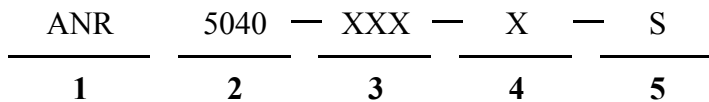

1.SERIES NAME

2.DIMENSIONS

3.TYPE

4.INDUCTANCE

5.TOLERANCE CODE: J:±5% K:±10% L:±15% M:±20% P:±25% N:±30%

6.INTERNAL IDENTIFICATION

2.FEATURES:

- Magnetic-resin shielded coANRuction reduces buzz noise to ultra-low levels
- Metallization on ferrite core results in excellent shock resistance and damage-free durability
- Closed magnetic circuit design reduces leakage flux and Electro Magnetic Interference (EMI)
- 30% higher current rating than conventional inductors of equal size
- Takes up less PCB real estate and save more power

3.APPLICATIONS

- LED Lighting
- Next-generation mobile devices with multifunction such as mobile TV and digital movie cameras
- Flat-screen TVs, blue-ray disc recorders, set top box
- Notebooks, desktop computers, servers, graphic cards cards
- Portable gaming devices, personal navigation systems, personal multimedia devices
- Automotive systems
- Telecomm base stations

【SPECIFICATION FOR APPROVAL】

SAN TUO P/N	ANR5040 Series	DATE	2015/11/10	REV	B
-------------	----------------	------	------------	-----	---

1. Appearance shape (unit : mm)

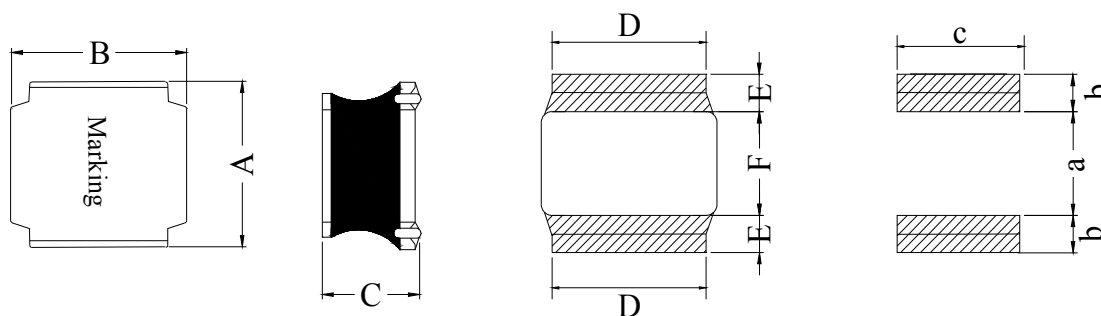

Top View

Front View

Bottom View

Recommended Land Pattern

2. Appearance size(unit : mm) Tolerance:

A	B	C	D	E	F	a	b	c		
5.0±0.2	5.0±0.2	4.0Max	4.0 Typ	1.25 Typ	2.5Typ	2.3Typ.	1.4Typ.	4.2Typ.		

3. Test instruments

L: TH2826A LCR METER (or equivalent)

Isat: CH2815 LCR METER+VR7220 DC SUPPLIER (or equivalent)

DCR: HK502BC MILLIOHMMETER (or equivalent)



【SPECIFICATION FOR APPROVAL】

SAN TUO P/N	ANR5040 Series	DATE	2015/11/10	REV	B
-------------	----------------	------	------------	-----	---

4. CHARACTERISTICS

P/N	Inductance 电感 @100KHz,1.0V	DC Resistance 直流电阻 (±30%)	Saturation Current 饱和电流	Heat Rating Current 温升电流	Marking 印字
Units	uH	Ω	A	A	
Symbol	L	DCR	Isat	Irms	
ANR5040-1R0N	1.0±30%	0.013	7.35	4.90	1R0
ANR5040-1R5N	1.5±30%	0.015	6.30	4.30	1R5
ANR5040-2R2N	2.2±30%	0.019	4.90	3.80	2R2
ANR5040-2R7N	2.7±30%	0.022	4.30	3.60	2R7
ANR5040-3R3N	3.3±30%	0.024	3.95	3.40	3R3
ANR5040-3R9N	3.9±30%	0.027	3.55	3.20	3R9
ANR5040-4R7N	4.7±30%	0.030	3.50	3.00	4R7
ANR5040-5R6M	5.6±20%	0.033	3.20	2.80	5R6
ANR5040-6R8M	6.8±20%	0.043	2.90	2.50	6R8
ANR5040-100M	10±20%	0.064	2.35	2.10	100
ANR5040-150M	15±20%	0.086	2.00	2.00	150
ANR5040-220M	22±20%	0.129	1.60	1.50	220
ANR5040-270M	27±20%	0.165	1.50	1.30	270
ANR5040-330M	33±20%	0.188	1.30	1.20	330
ANR5040-470M	47±20%	0.270	1.10	1.00	470
ANR5040-680M	68±20%	0.400	0.90	0.80	680
ANR5040-101M	100±20%	0.560	0.75	0.70	101

※1: All test data is referenced to 20° C ambient;
 ※2: Rated current: Isat or Irms, whichever is smaller;
 ※*3: Isat: DC current at which the inductance drops approximate 30% from its value without current;
 ※*4: Irms: DC current that causes the temperature rise (ΔT =40° C) from 20° C ambient.

【SPECIFICATION FOR APPROVAL】

SAN TUO P/N	ANR5040 Series	DATE	2015/11/10	REV	B
-------------	----------------	------	------------	-----	---

1.DIMENSIONS FOR CARRIER TAPES:

ITEM	W	A0	B0	K0	K1	P	F	E	D0	D1	P0	P2	T
DIM	12.00	5.30	5.30	4.3	0.00	8.00	5.50	1.75	1.50	1.50	4.00	2.00	0.4
	+0.3	+0.1	+0.1	+0.15	+0.0	+0.1	+0.15	+0.1	+0.1	+0.1	+0.1	+0.1	+0.05
	-0.3	-0.1	-0.1	-0.15	-0.0	-0.1	-0.15	-0.1	-0.0	-0.0	-0.1	-0.1	-0.05

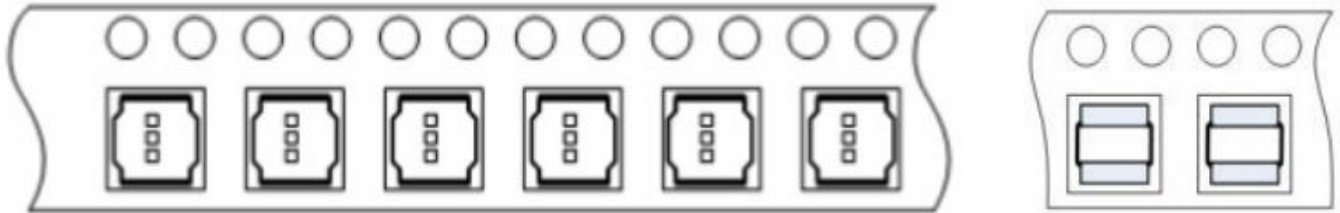
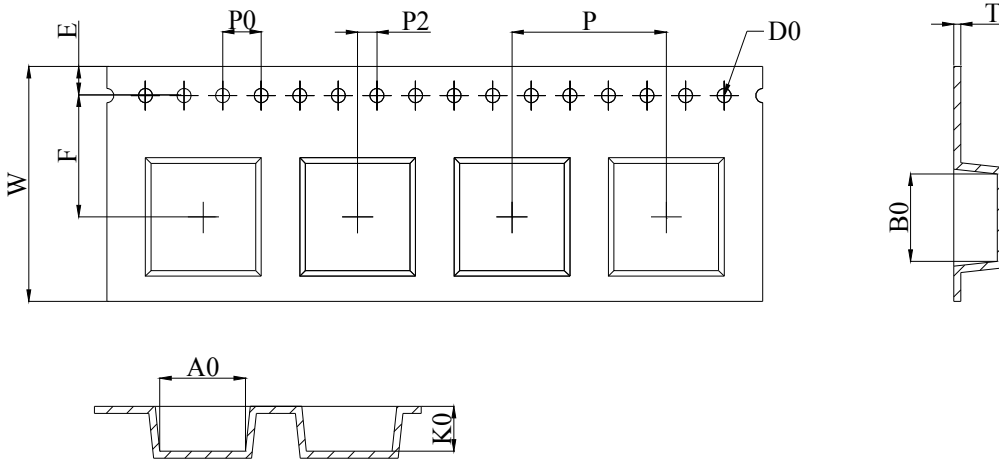

2.PACKING(mm)

载带宽度 (W)	间距 (P)	卷(PCS) 13inch	4卷/2袋 (PCS)	2袋/内箱 (PCS)	5内箱/外箱 (PCS)
12mm	8mm	1500	6000	6000	30000

备注:

1. 包装袋规格: 375*400mm (REF.) .
2. 内箱规格: 340*70*340mm (REF.) .
3. 外箱规格: 375*360*360mm (REF.) .